

## Sloping Tops for Lockers

### Description:

Fabricated sloping box cover, factory-fitted to nested locker units. Comprises top and rear cover section, with end and interim triangular supporting panels.

Material is mild steel, cold rolled, 0.5mm gauge, riveted assembly. Powder-coated light grey RAL 7035 as standard.



### Application:

Sloping tops prevent litter and other items being left on locker tops and are easier to keep clean than the standard flat top.

Appropriate to most changing areas, sloping tops are an essential feature for lockers in hygiene sensitive areas - particularly hospitals and the food industry.

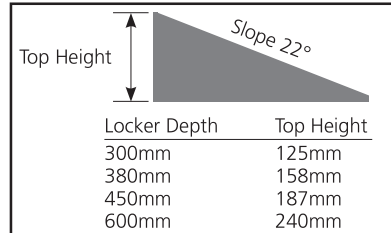

Sloping top components

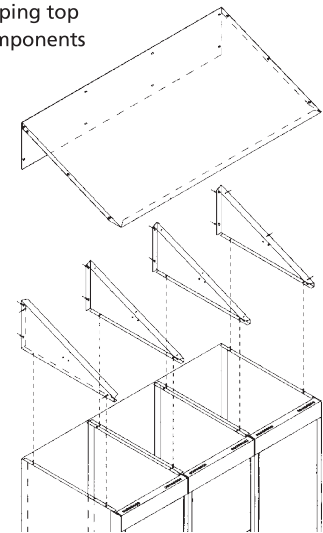

## Locker Stands

### Application:

Locker support stands are used to raise lockers from the surface of the floor.

### Benefits are:

- Minimises damage and wear to the base of the supported lockers
- Allows cleaning of the floor under lockers
- Adjustable feet allow level installation of lockers on a sloping floor
- Raises lockers above a floor which may sometimes be damp - during cleaning for example - to reduce the risk of corrosion

Support stands are also available extended in front of the lockers to carry a slatted seat.

### Material & Finish:

25mm square welded steel tube legs and support frame, with welded box-section fixing lugs, painted light grey RAL 7035 as standard.

Plastic feet are height adjustable 0-10mm as standard.

Seat units fitted with hard wood slats with clear lacquer finish, 30mm thick as standard, or 38mm thick polymer slats with black paint brushed on cut ends. If cut on site, cut ends are not visible, therefore lacquer or paint not applied.

Two slats are fitted as standard. An optional 3rd slat can be specified.

### Installation:

With the locker assembly positioned on the locker stand, drill 4mm diameter holes through the base shelf into the stand fixing lugs.

The holes used for mounting the hanging rails to the shelves are generally used as pilot holes for drilling points through into the stand lugs.

1x rivet is needed per stand fixing lug. The rivets are the same as used when nesting the lockers (see Page F2). Alternatively, if rivet guns are unavailable, no.6x30mm TEK screws can be used.

If fixing lugs are not provided on the stands, the locker must be ordered with the base shelf inverted. The rivets can then go through the shelf directly into the stand.

If the locker has an inverted base shelf or narrow bottom horizontal (e.g. half height and quarto lockers), the stand must be ordered without the fixing lugs.

Locker Stand

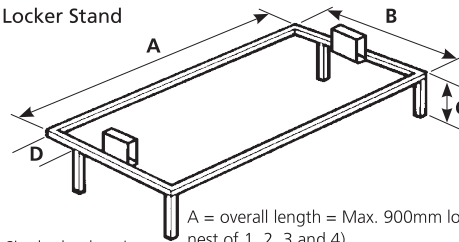

Single depth unit shown. Double-depth units also available for back to back runs

A = overall length = Max. 900mm locker nested width (to support nest of 1, 2, 3 and 4).

B = overall depth = locker depth +300 or 450mm seat

C = frame height with adjustable foot = 150mm + 10mm adjustment.  
D = rear leg is inset 50mm as standard, but can be inset 150mm to clear skirting.



Locker Stand with seat

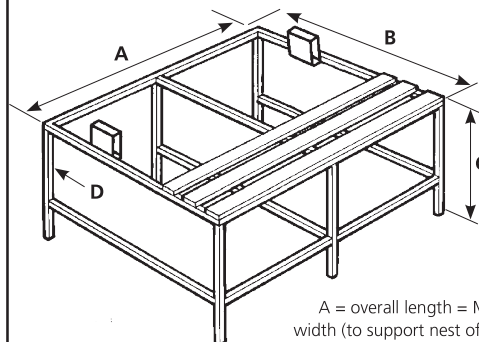

Single depth unit shown. Double-depth units also available for back to back runs

A = overall length = Max. 900mm locker nested width (to support nest of 1, 2, 3 and 4).

B = overall depth = locker depth +300mm seat

C = overall height with adjustable foot = 430mm (with timber slats), or 438mm (with polymer slats) + 10mm adjustment.

D = rear leg is inset 50mm as standard, but can be inset 150mm to clear skirting.



Two slats are fitted as standard. An optional 3rd slat can be specified.

Stand to Locker Fixing Lugs (detail inset)

